

DMXB SERIES BRACKETED TOWERS

WARNING: INSTALLATION OF THIS PRODUCT NEAR POWER LINES IS DANGEROUS! FOR YOUR SAFETY, FOLLOW THE INSTALLATION DIRECTIONS. SEE SAFETY INSTRUCTIONS.

DANGER



Delhi Towers are designed and built to stand up for years against severe wind and ice conditions. Although all towers are carefully made and inspected before they leave our factory, they are not guaranteed against failure due to shipping damage, over-loading or improper installation. Please read instructions carefully.

CHECK TOWER OVER

Inspect all tower sections on delivery to make sure there are no loose or broken rivets caused by transport mishandling. If a rivet is broken or loose it should be replaced by a snug fitting bolt and nut securely tightened. If legs are severely bent, make a damage claim against the transport company. Do not use damaged sections.

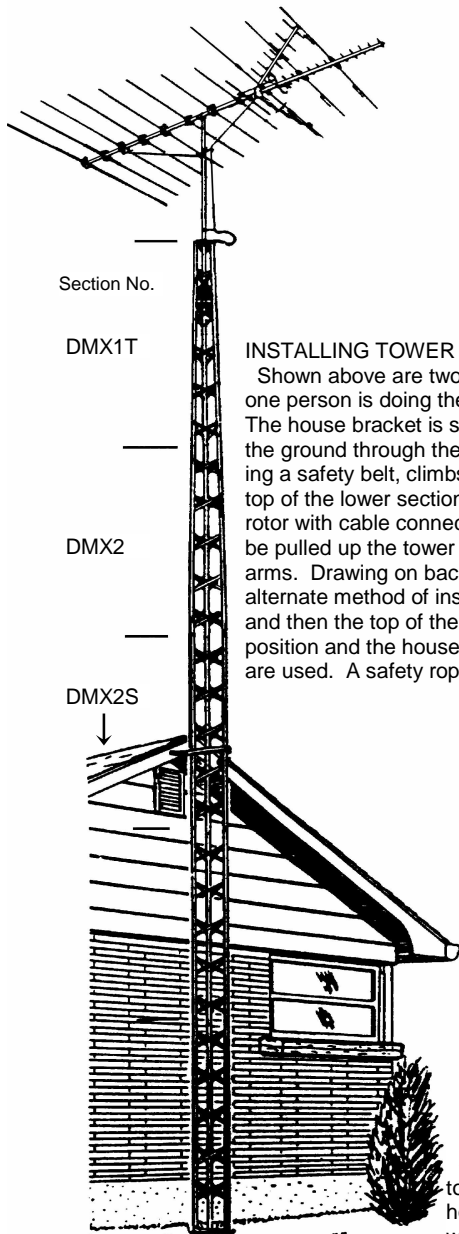

DMXB-5 44 ft. Tower

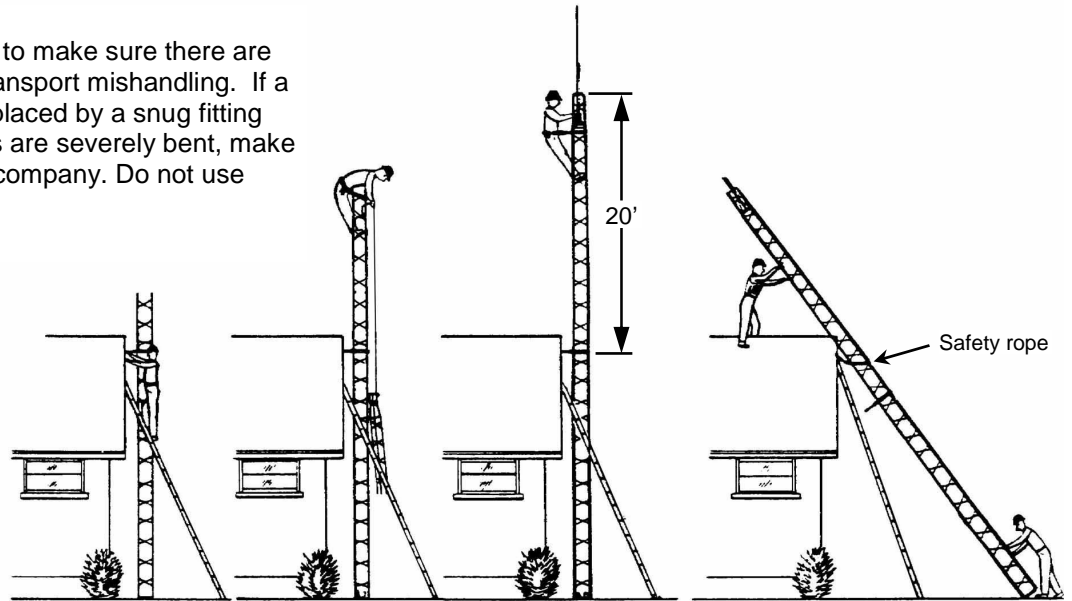

Figure 1

Figure 2

Figure 3

Figure 4

INSTALLING TOWER

Shown above are two methods of installing DMXB series towers on a house with a gable end. Method one is best used when only one person is doing the installing. Two or three tower sections are fastened together on the ground and pushed up against the house. The house bracket is secured to the house by two 3/8" dia. lag screws (not supplied) (see Figure 1). The 3' base stubs are driven into the ground through the three holes in the base plate after checking the vertical position of all three legs with a level. The installer, wearing a safety belt, climbs the tower and pulls the next section up using a rope and hook as in Figure 2. This section is fitted inside the top of the lower section. Stop rivets prevent the upper section dropping too far inside. Insert all bolts and tighten nuts securely. Install rotor with cable connected. Attach antenna to mast. Leave centre elements of antenna folded on one side so antenna and mast can be pulled up the tower easier. A gin-pole is handy for raising sections and the antenna, because it relieves strain on the installer's arms. Drawing on back shows construction. Gin-pole acts like a derrick and is hooked into the "x" braces, straddle the tower leg. The alternate method of installing the tower requires at least two people (see Figure 4). The tower is assembled completely on the ground and then the top of the tower is raised to the roof where the antenna and mast are installed. The tower is then raised to its vertical position and the house bracket screwed into the house with two lag screws. Reinforcing may be necessary at points where lag screws are used. A safety rope or strap can be looped around tower until house bracket is secured.

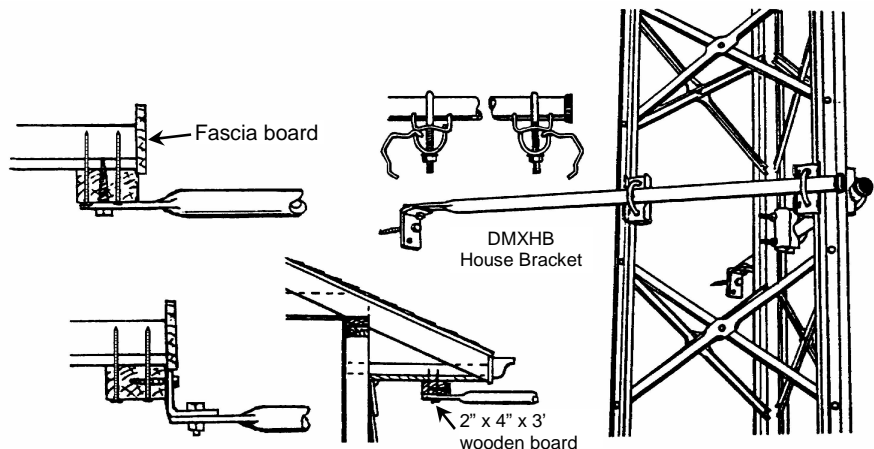

Shown above is a method of bracketing the DMXB tower to a house with an over hanging cottage roof. The house bracket is screwed to a 2" x 4" x 3' wooden board which is nailed or screwed to the wood under the eaves.

Assemble House Bracket and attach it to tower in approximate position with nuts finger tight. Bracket can be slid up and down between "X" braces until correct position is found. Turn lag screws into house and tighten bracket nuts securely.

IMPORTANT NOTE: The following procedure should be used when bolting tower sections together. Insert bolt through holes of the two sections. Place a lockwasher on the bolt and run the nut on. Only **ONE** lockwasher is required on each bolt and it is placed under the nut. Tighten the nut securely.

ANTENNA LOAD LIMIT

DMXB Towers are designed to support an antenna load of up to 3 square ft. wind area. This is equivalent to one large TV/FM antenna or two medium size TV/FM antennas, or one small VHF colinear or one small CB antenna. No more than 20 ft. of tower (2.5 sections) should be above the house bracket. Guy wires must be used if larger loads or greater height using more sections is needed. Use GS12 listed below.

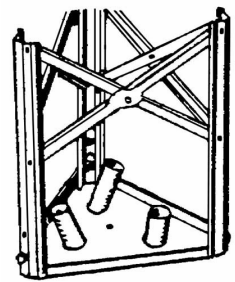

Three 3 ft. base stubs (not supplied) are driven into the ground through the holes in the base plate to locate the tower base after the tower legs are positioned vertically.

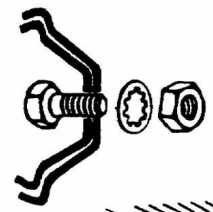
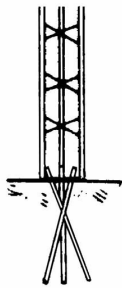

INSTALLING MAST

Two U-Bolt assemblies with "L" brackets are supplied for installing the mast. These "L" brackets are bolted through the slotted holes on each plate with the short leg of the "L" bracket toward the outside of the tower. Adjustments to make the mast vertical may be made by moving the "L" bracket in the slotted holes.

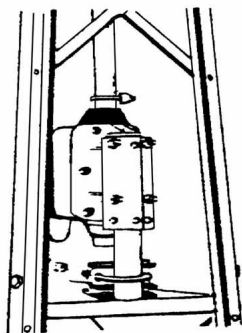
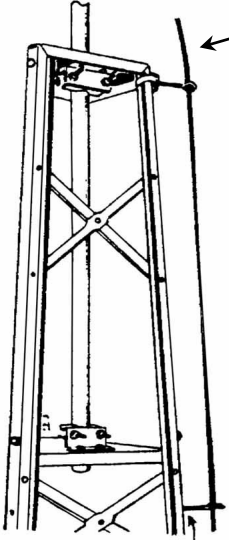

Alliance, RCA & Blonder-Tongue

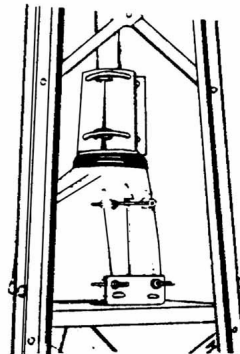

Crown, Archer & Channel-Master

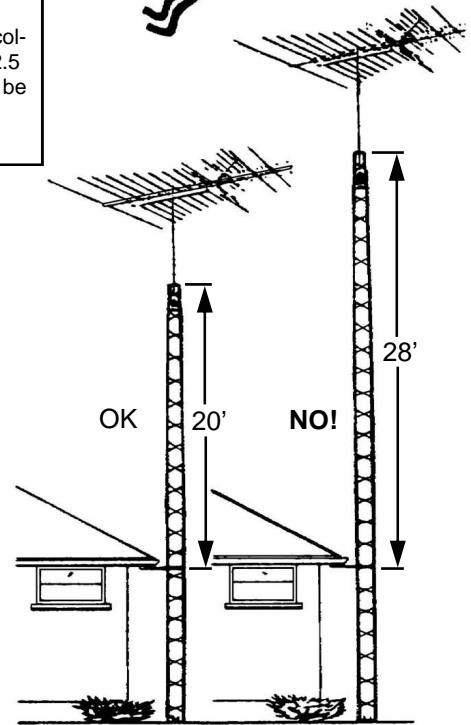

INSTALLING ROTORS

Any make of rotor can be installed on the rotor plate provided inside the top section of a DMXB tower for a neat appearance and also to make use of the mast thrust bearing on the top plate which increases rotor life considerably. The CDE Model AR-30, Crown and Channel-Master rotors can be mounted directly to the "L" bracket as shown at left and above. The Alliance, Superior, Blonder-Tongue rotors need an 8" piece of masting held by the mast clamp as shown above left. The CDE Models AR-40 and AR-33 can be directly installed by discarding the cast base and using 3/8" hex nuts as spacers between rotor and tower rotor plate. Insert the four 1/4-20 bolts, supplied with rotor, up through the 4 plate holes and spacers into rotor and tighten securely.

Rotor cable and TV coax. cable can be run down the outside of the tower leg and held in place every four to six feet by waterproof tape. 300 ohm lead-in can be supported by wrap-around standoffs placed 6 to 8 ft. apart on the tower legs.

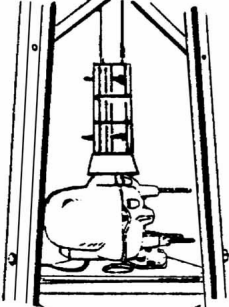

CDE AR-30

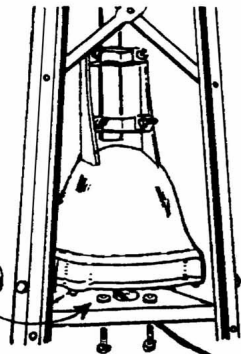

CDE AR-40

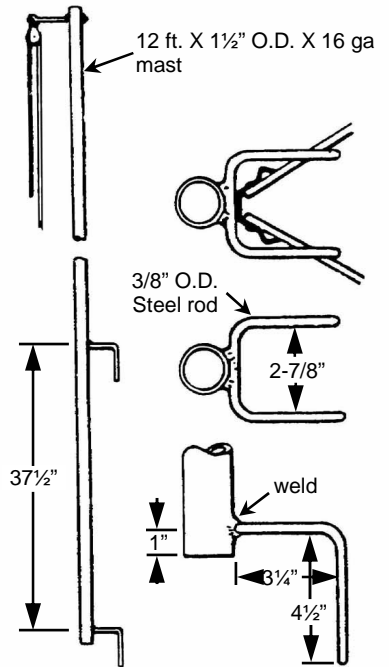

GUYED DMXB TOWERS

DMXB towers can be guyed up to a height of 80 ft. using 10 sections. A GS12 guy station should be used every three sections from the ground up. The top guy station should be attached to the middle of the top section. Regular TV guy wire can be used. Ground guy anchors must be spaced 120 degrees apart and about one half the tower height or more away from the base of tower. Try to maintain uniform tensions on all guy wires, but do not tighten them excessively.

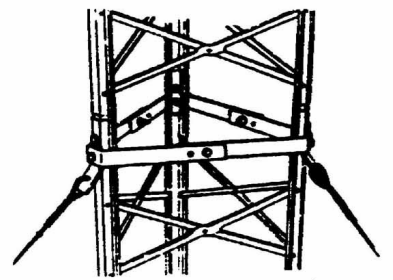

GS123 Guy Station

WADE
ANTENNA

www.wadeantenna.com